

# CDF Series

## 乾式單板電磁離合器-法蘭固定型 Electromagnetic Power-Applied Friction Clutch - Flange Mounted

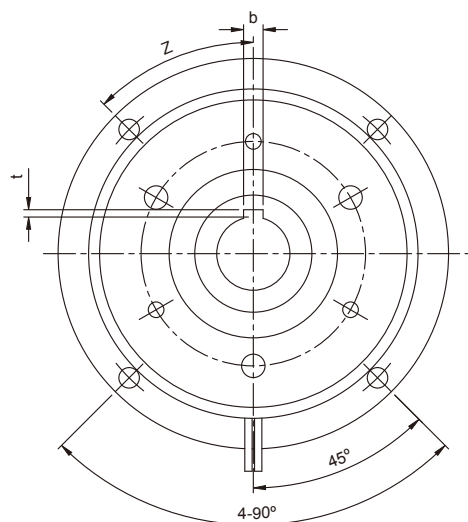
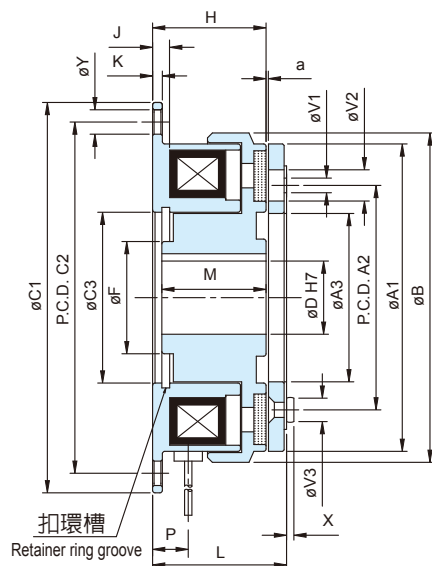
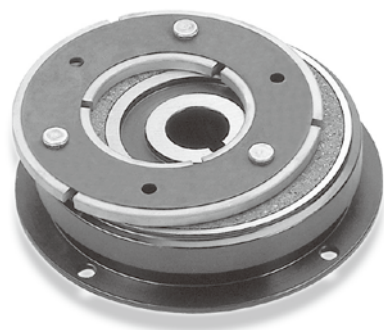

型號 MODEL	CDF0S6AA(AB)	CDF1S5AA(AB)	CDF2S5AA(AB)	CDF005AA(AB)	CDF010AA(AB)	CDF020AA(AB)	CDF040AA(AB)		
靜摩擦轉距 [kgm](Nm) Static Friction Torque	0.55 (5.5)	1.1 (11)	2.2 (22)	4.5 (45)	9 (90)	17.5 (175)	35 (350)		
動摩擦轉距 [kgm](Nm) Dynamic Friction Torque	0.5 (5.0)	1.0 (10)	2.0 (20)	4 (40)	8 (80)	16 (160)	32 (320)		
功率 Power [24V](W) at 20°C	11	15	20	25	35	45	60		
徑方向 Radius	A1	63	80	100	125	160	200	250	
	A2	46	60	76	95	120	158	210	
	A3	34.5	41.8	52	62	80	99.5	125	
	B	67.5	85	106	133	169	212.5	264	
	C1	80	100	125	150	190	230	290	
	C2	72	90	112	137	175	215	270	
	C3	35	42	52	62	80	100	125	
	D	15(12)	20(15)	25(20)	30(25)	40(30)	50(40)	60(50)	
	F	23(21)	28	40	45	62	77	100	
	V1	3-3.1	3-4.1	3-5.1	3-6.1	3-8.1	3-10.2	4-12.2	
	V2	3-6.3	3-8	3-12	3-12.5	3-15	3-17.3	4-20.8	
	V3	3-6	3-6	3-7.5	3-9.8	3-13	3-18	4-23	
	Y	5	6	7	7	9.5	9.5	11.5	
Z	6-60°						8-45°		
軸方向 Shaft	H	24	26.5	30	33.5	37.5	44	51	
	J	3.5	4.3	5	5.5	6	7	7.85	
	K	2	2.5	3	3.5	4	5	6	
	L	28.05	31.3	35.9	40.5	47	56.2	64.47	
	M	22	24.1	27	30	33	40.15	47.15	
	P	7.5	9.5	8.9	9.5	9.5	10.5	15.5	
	X	1.5	1.4	1.7	2	2.5	5.7	6.4	
	a	0.2 (±0.05)			0.3 (+0.05/-0.1)		0.5 (0/-0.2)		
	b	5 (4)	5 (5)	7 (5)	7 (7)	10 (7)	12 (10)	15 (12)	
	t	2.3(1.8)	2.3(2.3)	3.3(2.3)	3.3(3.3)	3.8(3.3)	3.8(3.8)	5.3(3.8)	
重量 Weight (kg)	0.46	0.83	1.5	2.76	5.1	9.3	17		
保護索子 Protective device	07D470K	07D470K		10D680K	14D680K		20D680K		